

SBIR Circulaire Viaducten

Honeycomb

Team: Studio RAP, Bruil, Movares, Dywidag, K_Dekker



Honeycomb : Studio RAP, Bruil, Movares, Dywidag, K_Dekker

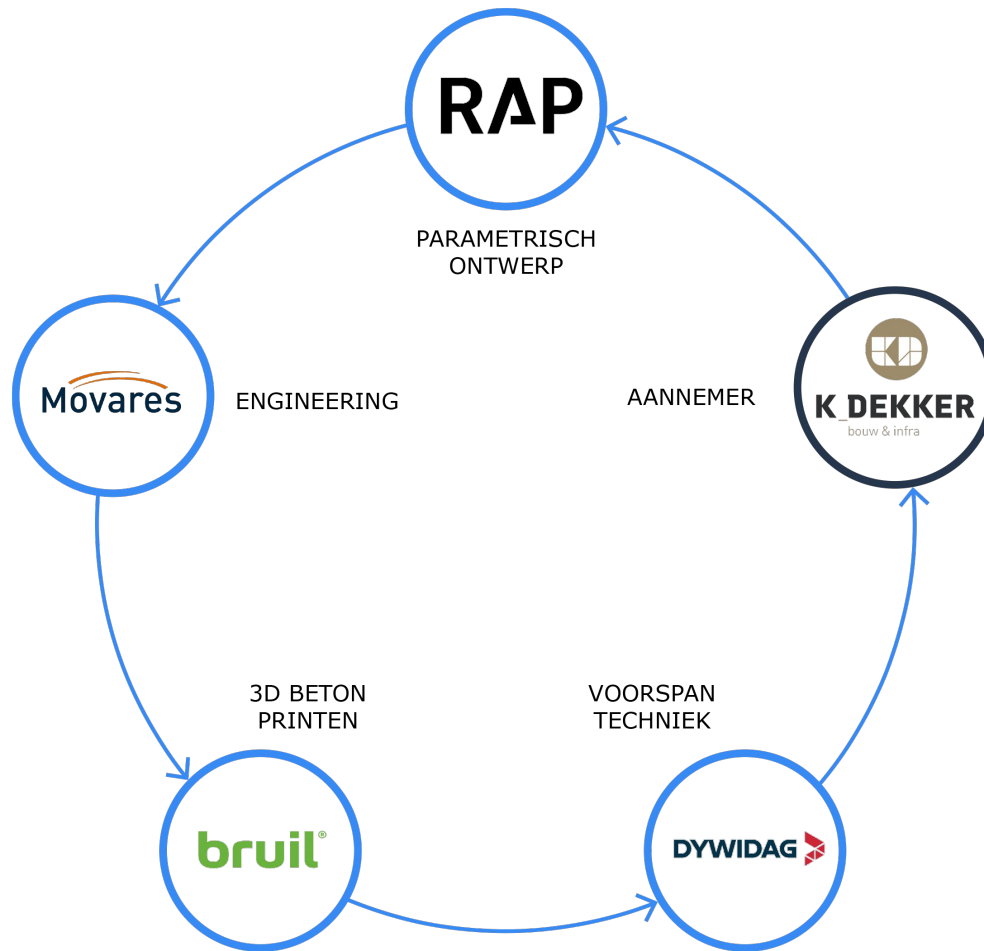

kokon
ARCHITECTUUR & STEDENBOUW



HelderVastgoed





Honeycomb : Studio RAP, Bruil, Movares, Dywidag, K_Dekker

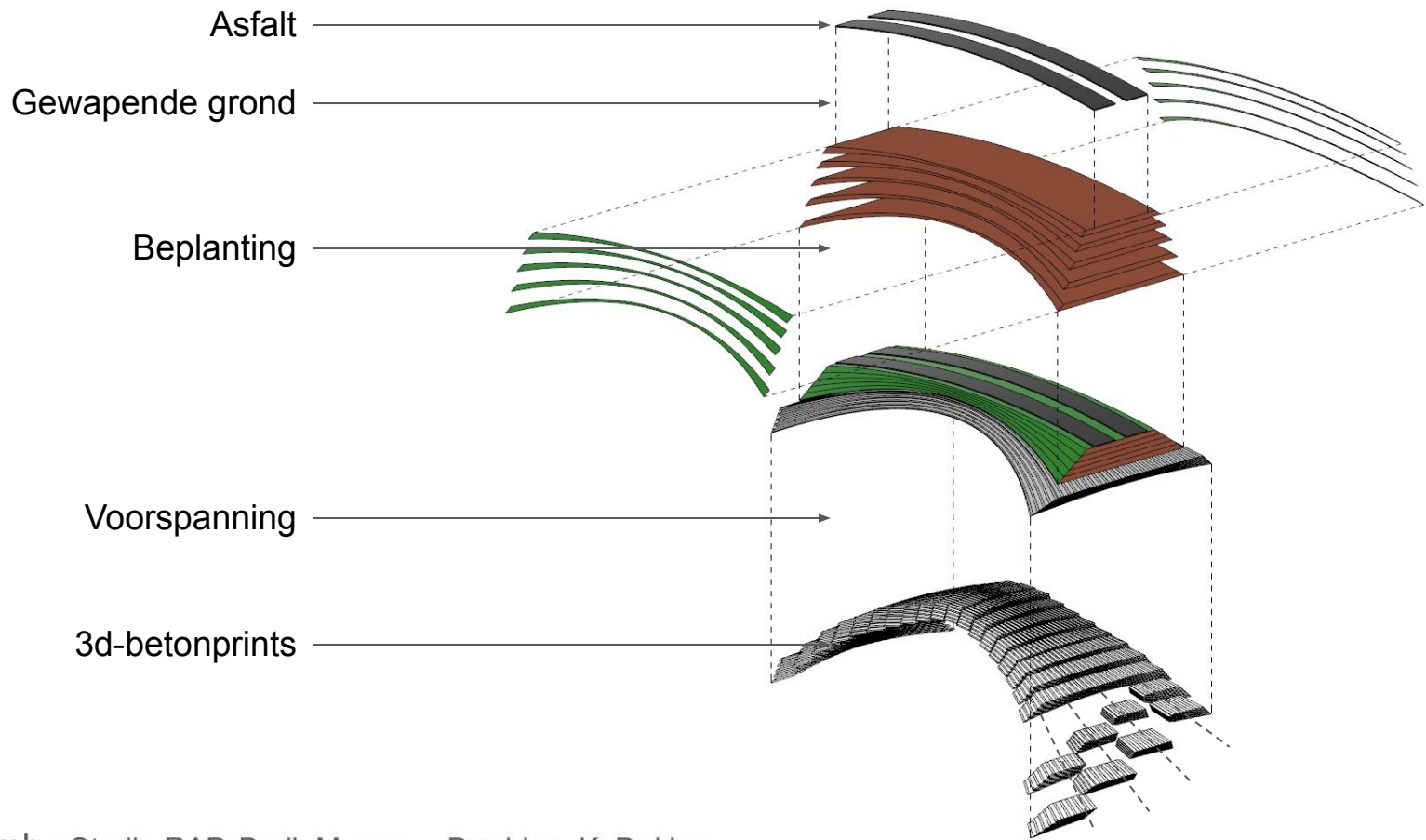

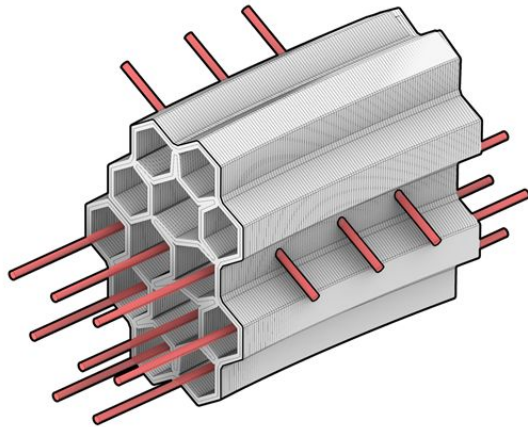
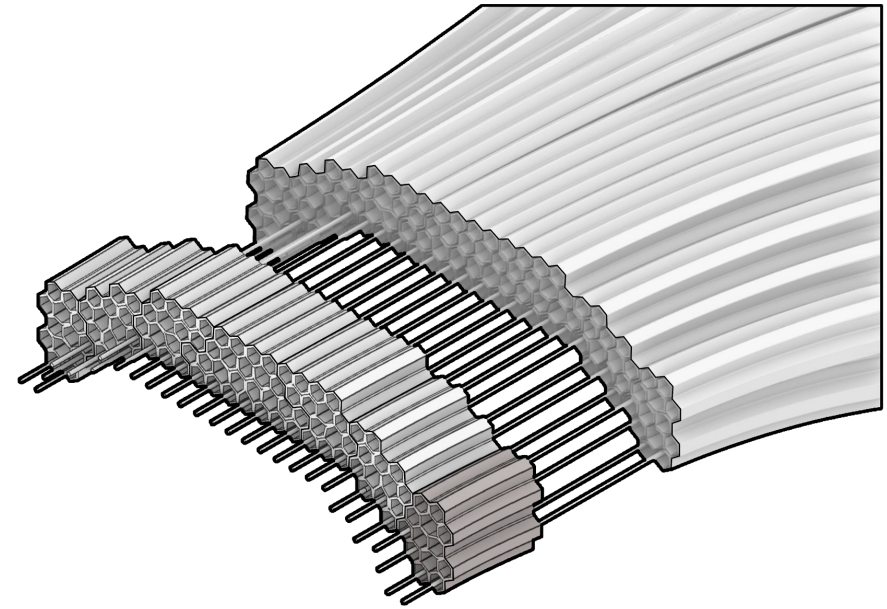
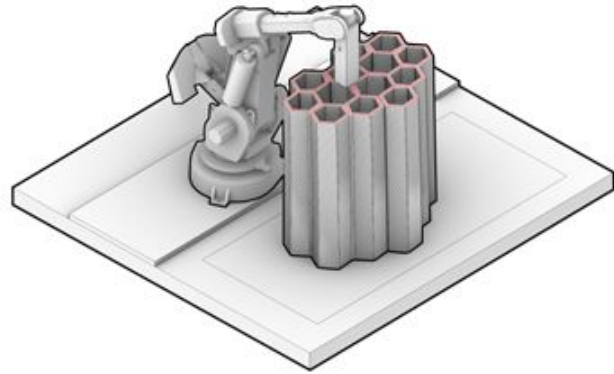

Honeycomb : Studio RAP, Bruil, Movares, Dywidag, K_Dekker

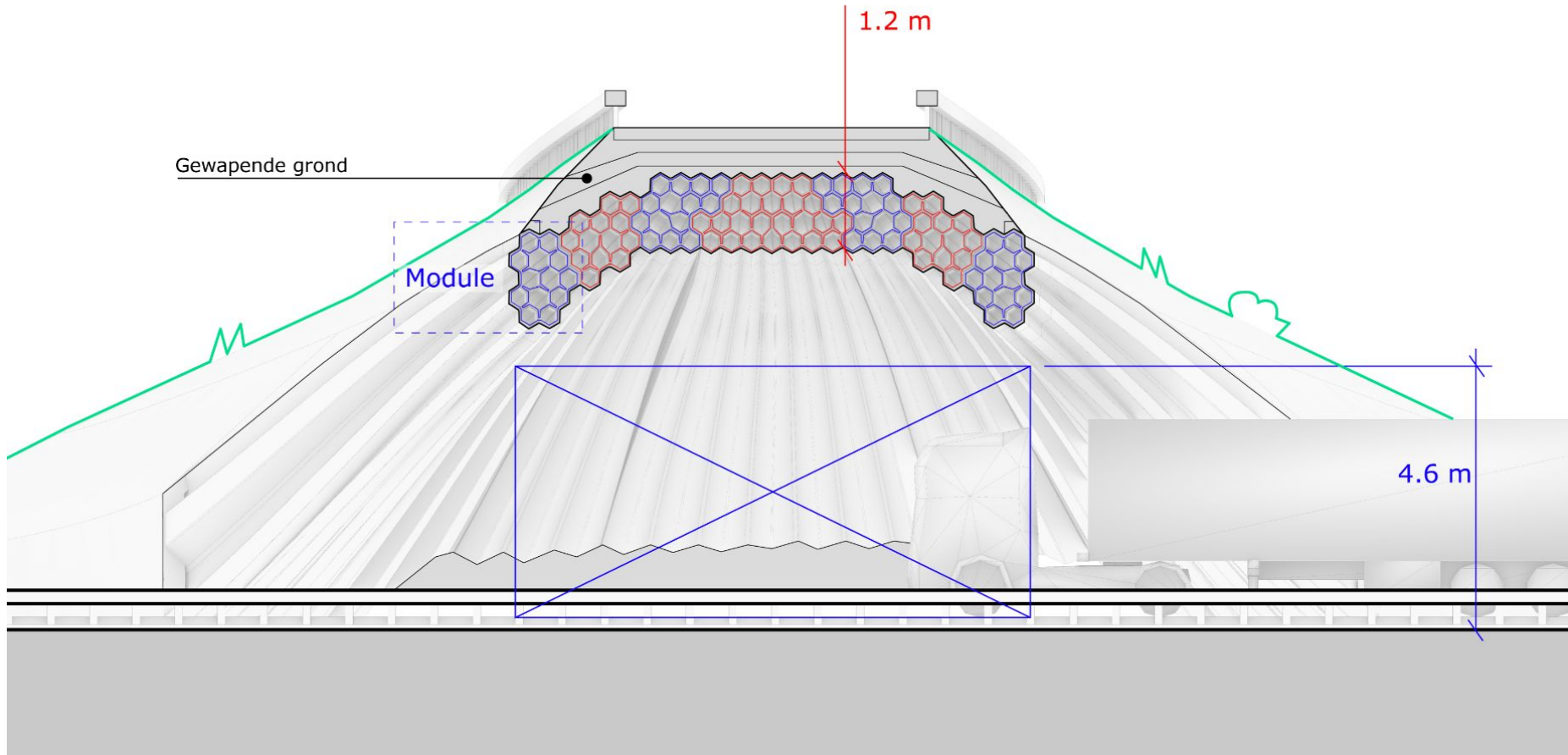

Honeycomb : Studio RAP, Bruil, Movares, Dywidag, K_Dekker

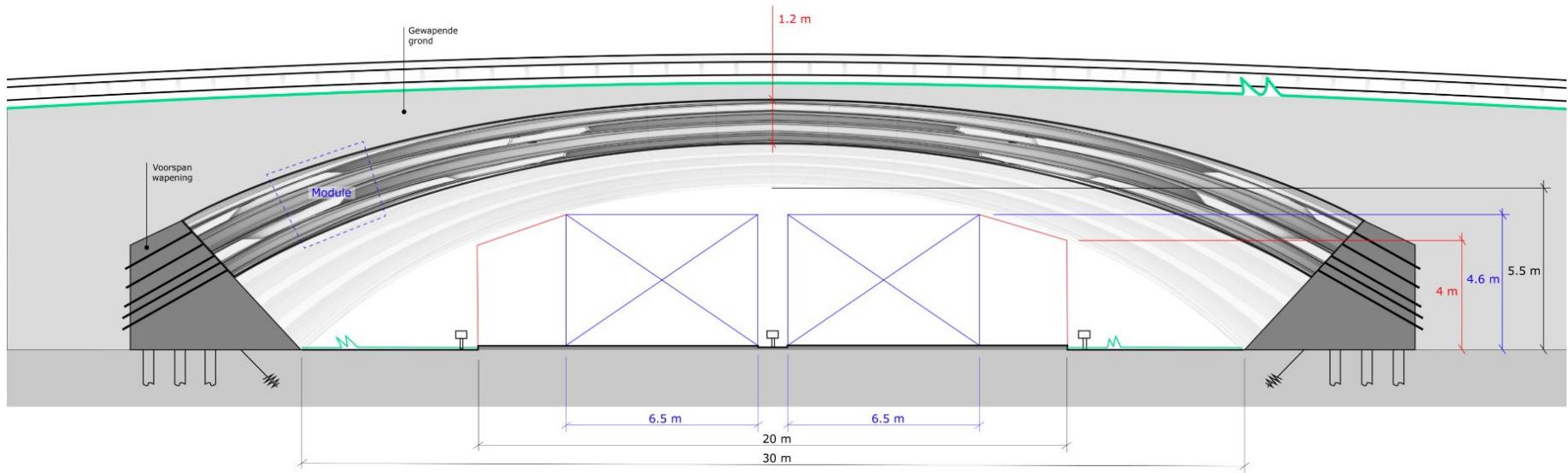

Circulariteit

zo min mogelijk materiaal (refuse)
oneindig herbruikbaar is. (re-use)
een zo laag mogelijke CO2 impact (reduce)
componenten die losmaakbaar en vervangbaar zijn

Meest duurzaam

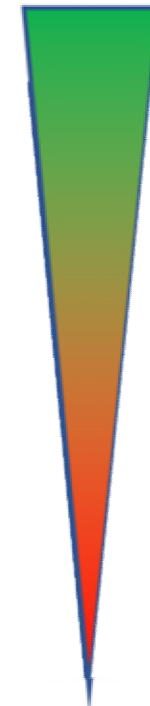

Refuse

Reduce

Redesign

Re-use

Repair

Refurbish

Remanufacture

Re-purpose

Recycle

Recover

Minst duurzaam

Material besparing

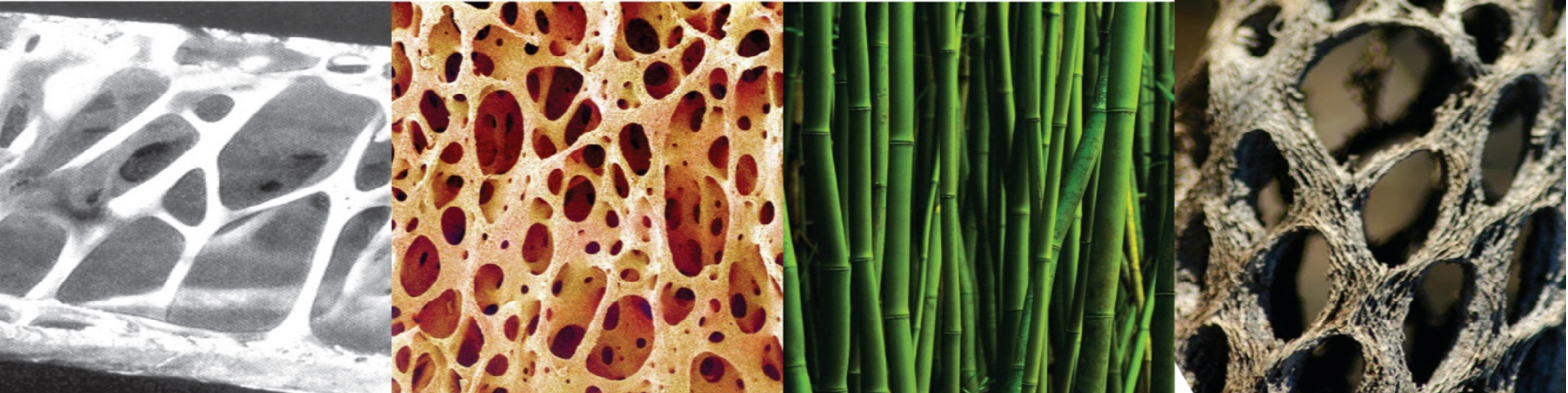

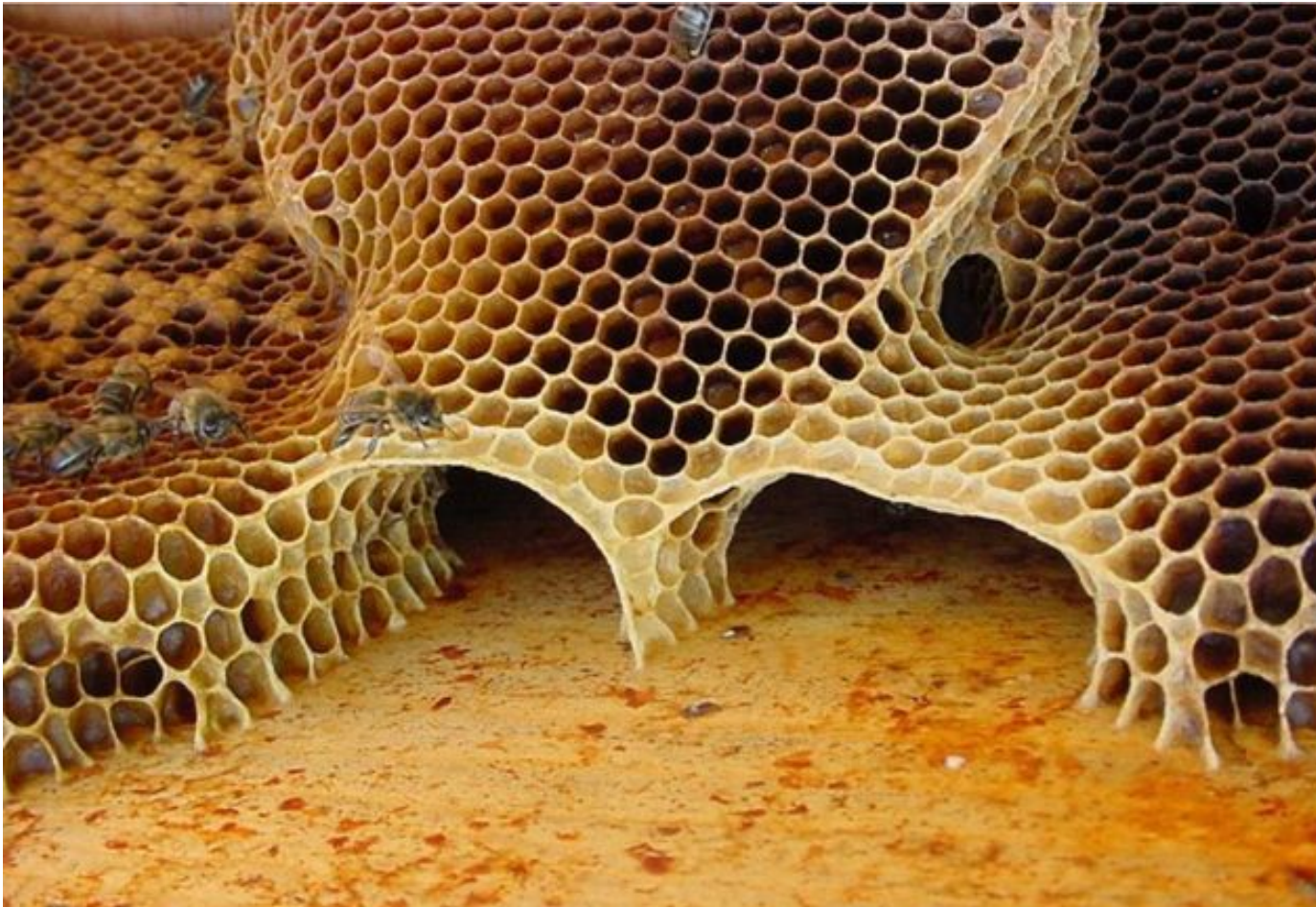

Honeycomb : Studio RAP, Bruil, Movares, Dywidag, K_Dekker

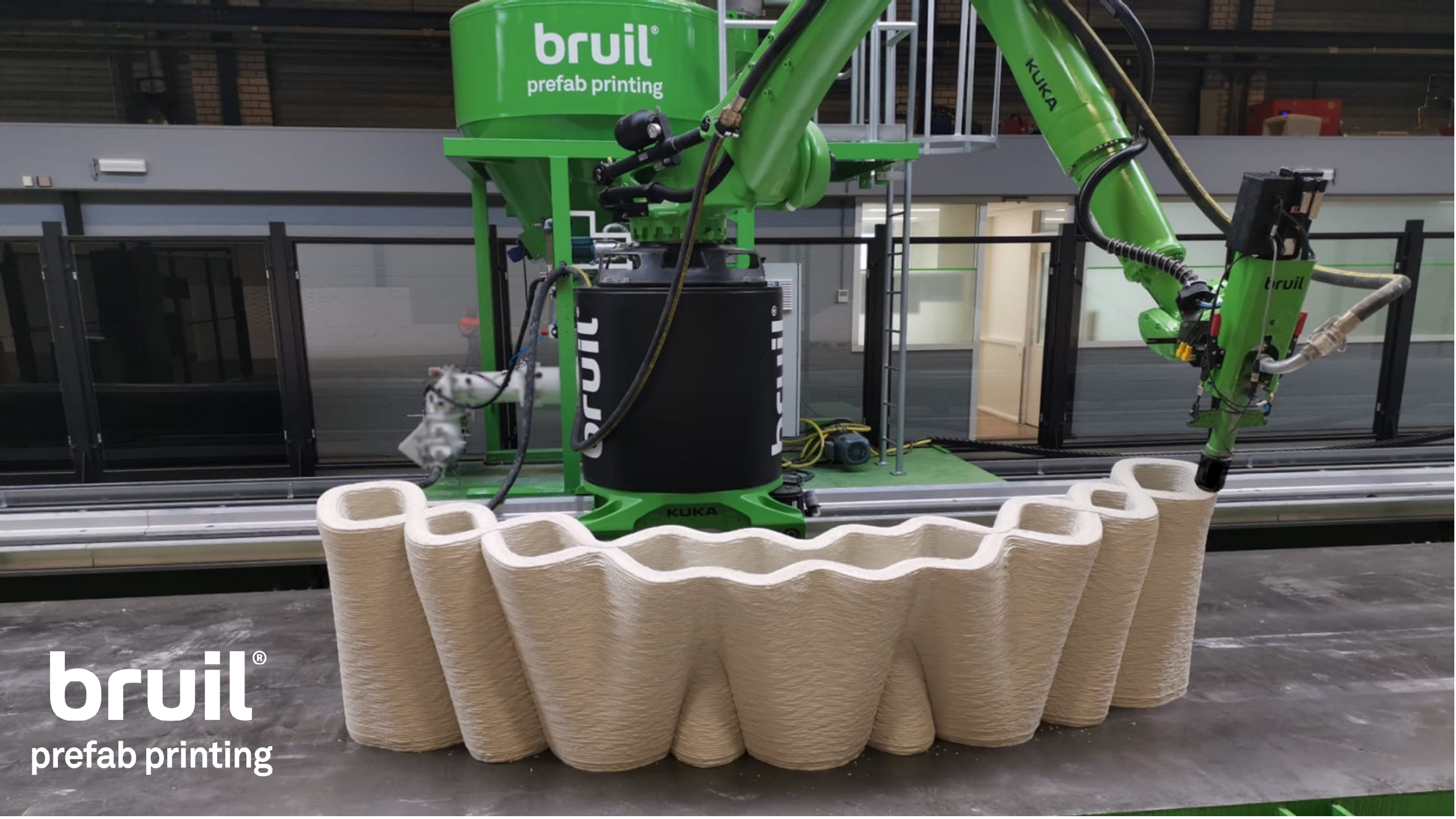

bruil[®]
prefab printing

KUKA

bruil

KUKA

bruil[®]
prefab printing

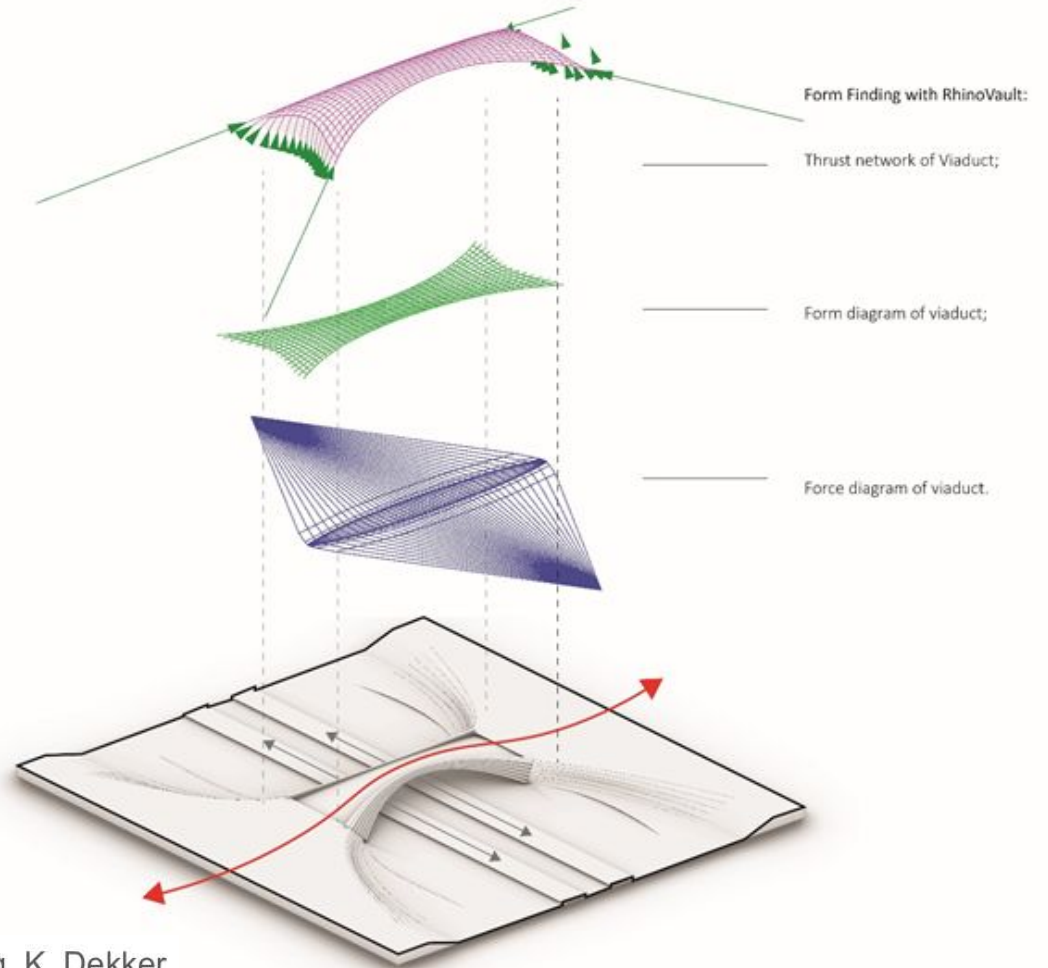
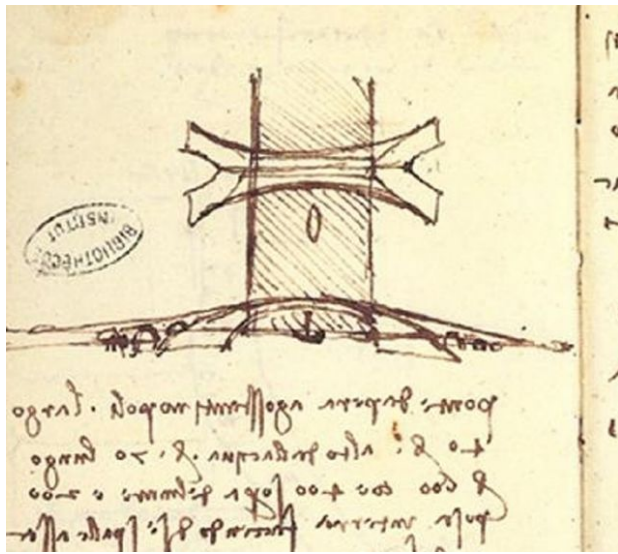

Honeycomb : Studio RAP, Bruil, Movares, Dywidag, K_Dekker

Niet alleen inzetten op modulariteit

In 2070 krijgt een (bouw)bedrijf de opdracht om een (geprint) viaduct te vervangen...
Welke waarde moeten 'building blocks' voor de bouwers en engineers in 2070 hebben?



Opel Kadett 1986



Opel Astra 2021



Opel Astra 2026?

Re-use 80% modulair / 20% maatwerk

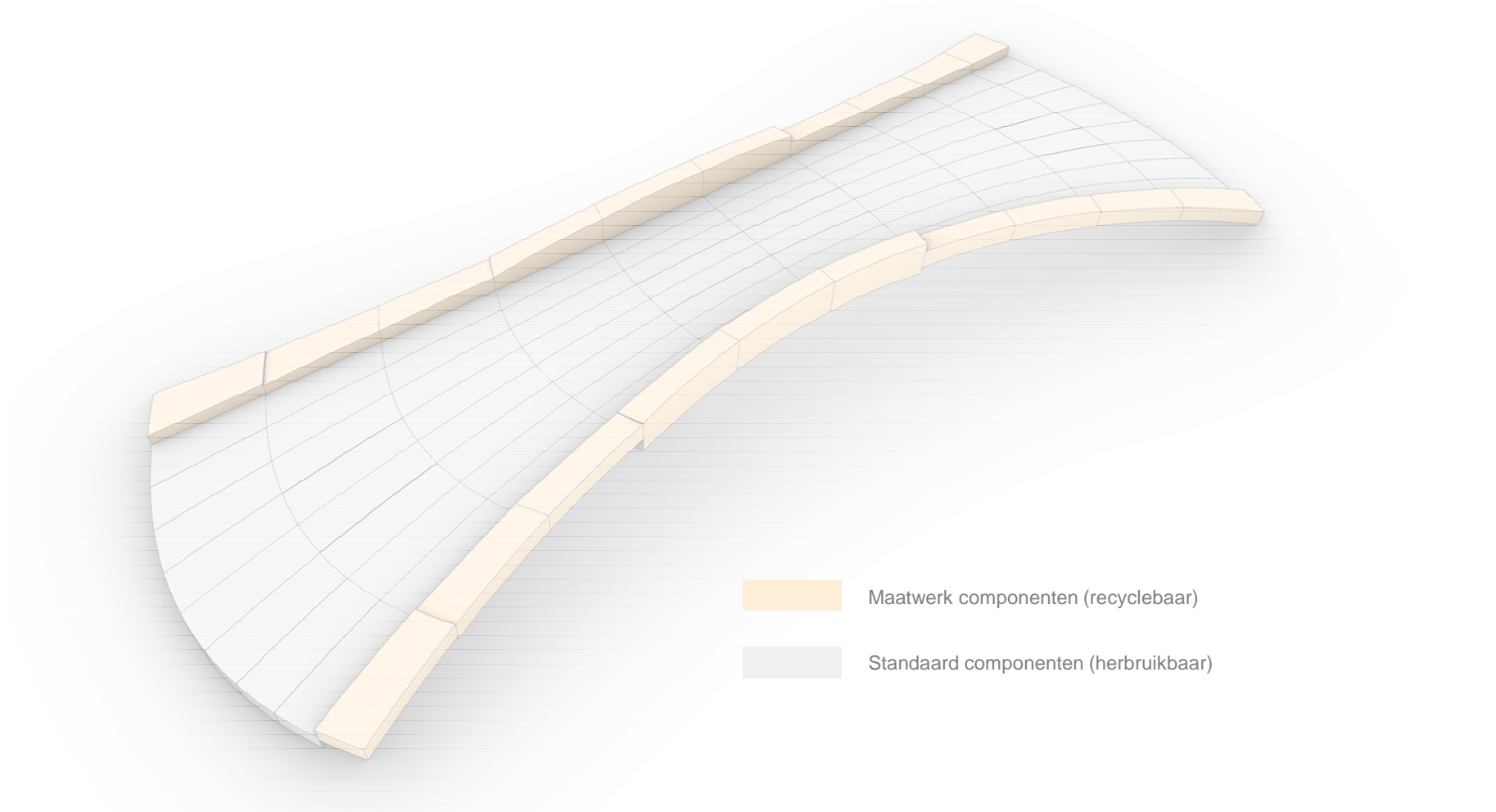

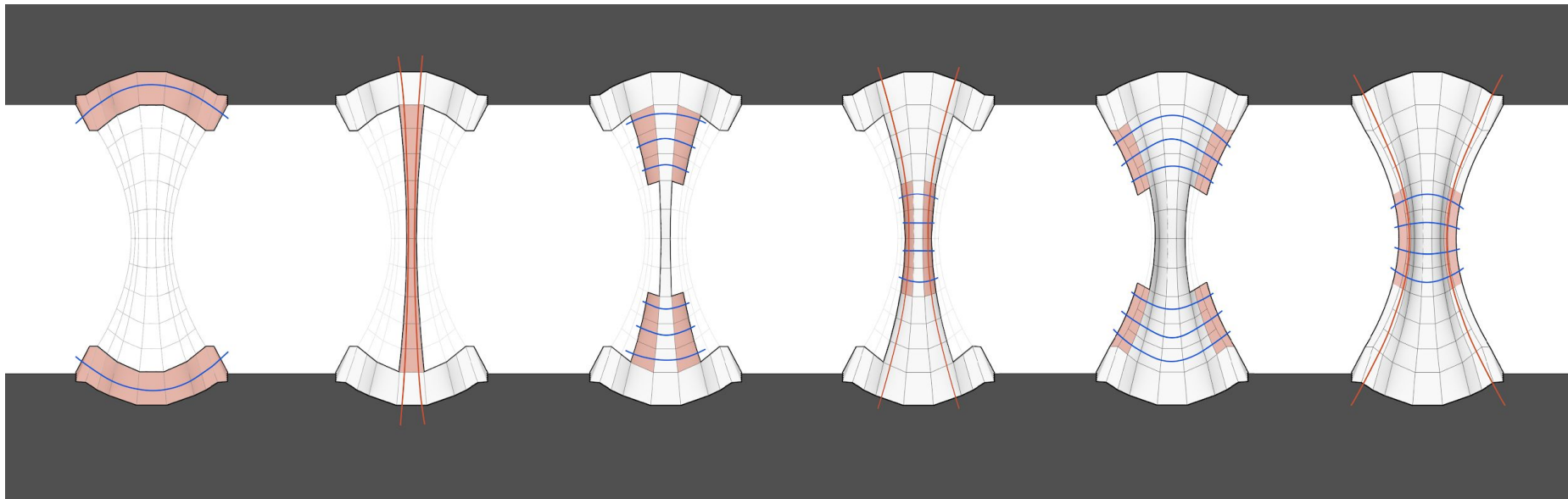

Honeycomb : Studio RAP, Bruil, Movares, Dywidag, K_Dekker



Honeycomb : Studio RAP, Bruil, Movares, Dywidag, K_Dekker